

Service Agreement

Experience the Best. No Fine Print. No Hidden Clauses.



Date Prepared:

Apr. 21, 2015

Prepared for:

Warren Banbridge
1906 Beechwood Avenue
Nashville TN 37212
615-720-8533

Prepared by:

Bruce Harborth
615-504-4591
bruce@usstn.com



Service Agreement

United Structural Systems, Inc., enters into this agreement with **Warren Banbridge**, to provide labor, equipment, and materials for the repairs listed below and shown on the attached drawing at **1906 Beechwood Avenue, Nashville TN 37212**. This agreement and its prices herein, are good for 90 days after issue.

Repair Plan

Code	Description	QTY	Units	Unit Price(\$)	Total(\$)	Transferable Warranty (see warranty detail below)
ADG	See contract diagram outlining all repair details.	1	-	0.00	0.00	-
ASC	Clean-up area of repair.	1	-	0.00	0.00	-
AGS	Seed & straw area of repair, as needed.	1	-	0.00	0.00	-
SIB	Install I-Beam with adjustable steel support post for floor support system.	2	ea.	200.00	400.00	5 years
SJE	Install adjustable steel support post, on existing concrete.	6	ea.	500.00	3,000.00	5 years

Additional Remarks

Customer to provide plumber for water line adjustments if needed for I beam install.

Agreement Total

Total Amount	\$3,400.00
Down Payment	\$ (0.00)
Balance Due	\$3,400.00
Credit Card Payments are subject to a 2.5% processing fee	

Transferable Warranty Detail

Transferable warranty(ies) associated with the service code(s) provided above:

Code	Detail
SIB	5 years of free post adjustments, if needed in area of repair.
SJE	5 years of free post adjustments, if needed in area of repair.

Repair Plan Comments

Repair comment(s) associated with the service code(s) provided above:

Code	Comment
SIB,SJE	USS will lift and correct settlement/deflection of floor as much as practical. Amount of correction can neither be predicted nor guaranteed. USS is not responsible for damage to drywall or floor materials.

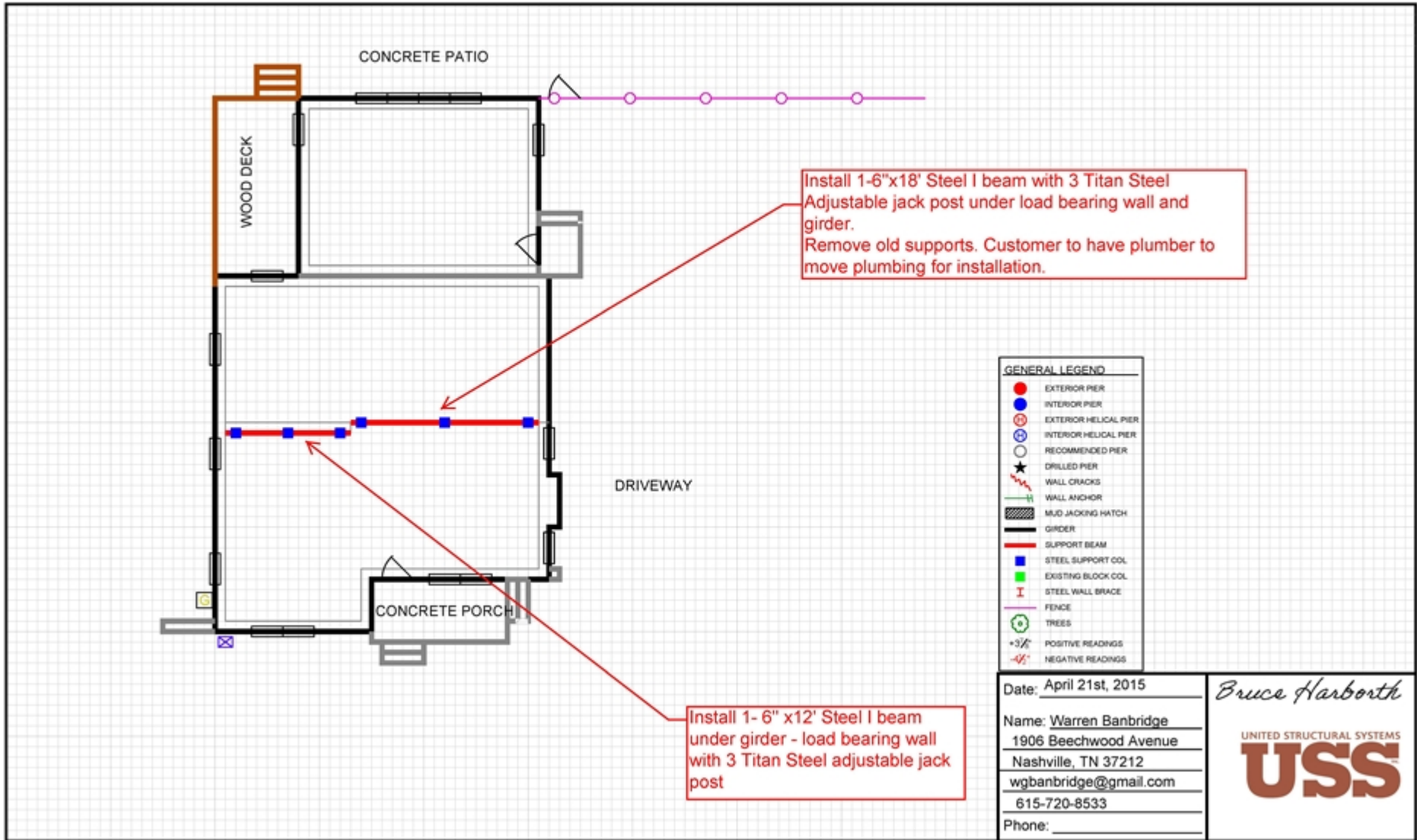

Date: April 21st, 2015

Name: Warren Banbridge
 1906 Beechwood Avenue
 Nashville, TN 37212
 wgbanbridge@gmail.com
 615-720-8533

Phone: _____

Bruce Harborth

UNITED STRUCTURAL SYSTEMS

USS

Service Agreement, con't.

Agreement Acceptance

The prices, specifications and conditions on this agreement are satisfactory and are hereby accepted. USS, Inc. is authorized to do the work as specified at this location: **1906 Beechwood Avenue, Nashville TN 37212**. Payment will be made upon completion of project. I understand that failure to pay USS, Inc. shall result in voiding of all warranties. I also understand that failure to pay USS, Inc. may result in my assuming any legal fees associated with USS, Inc.'s attempt to collect my unpaid balance. This agreement includes the attached job specific drawings.

Signature

Warren Banbridge
1906 Beechwood Avenue
Nashville TN 37212

USS Representative Signature

Bruce Harborth

Bruce Harborth
615-504-4591
bruce@usstn.com

Date:

Apr. 21, 2015

Buyer's Right To Cancel

You may cancel this agreement by contacting USS, Inc. prior to your scheduled start date.

No	Image
1	 A close-up photograph showing a large, horizontal pipe wrapped in silver insulation. A white Titan jack support is positioned vertically, supporting the pipe. Several dark I-beams are visible in the background, running parallel to the pipe. The scene is dimly lit, with a bright light source creating a glare on the pipe's surface.
1	<p>Run I beams and Titan jack supports parallel with Girders. Remove old supports. Water lines may need to be moved</p>
2	 A photograph showing a complex network of pipes, beams, and supports. A large, insulated pipe is visible in the foreground, similar to the one in the first image. Above it, there are several dark I-beams and a network of white and yellow pipes. The scene is dimly lit, with a bright light source creating a glare on the pipe's surface.

No	Image
2	Run support system under load bearing walls and girder

FLOOR SUPPORT DETAIL

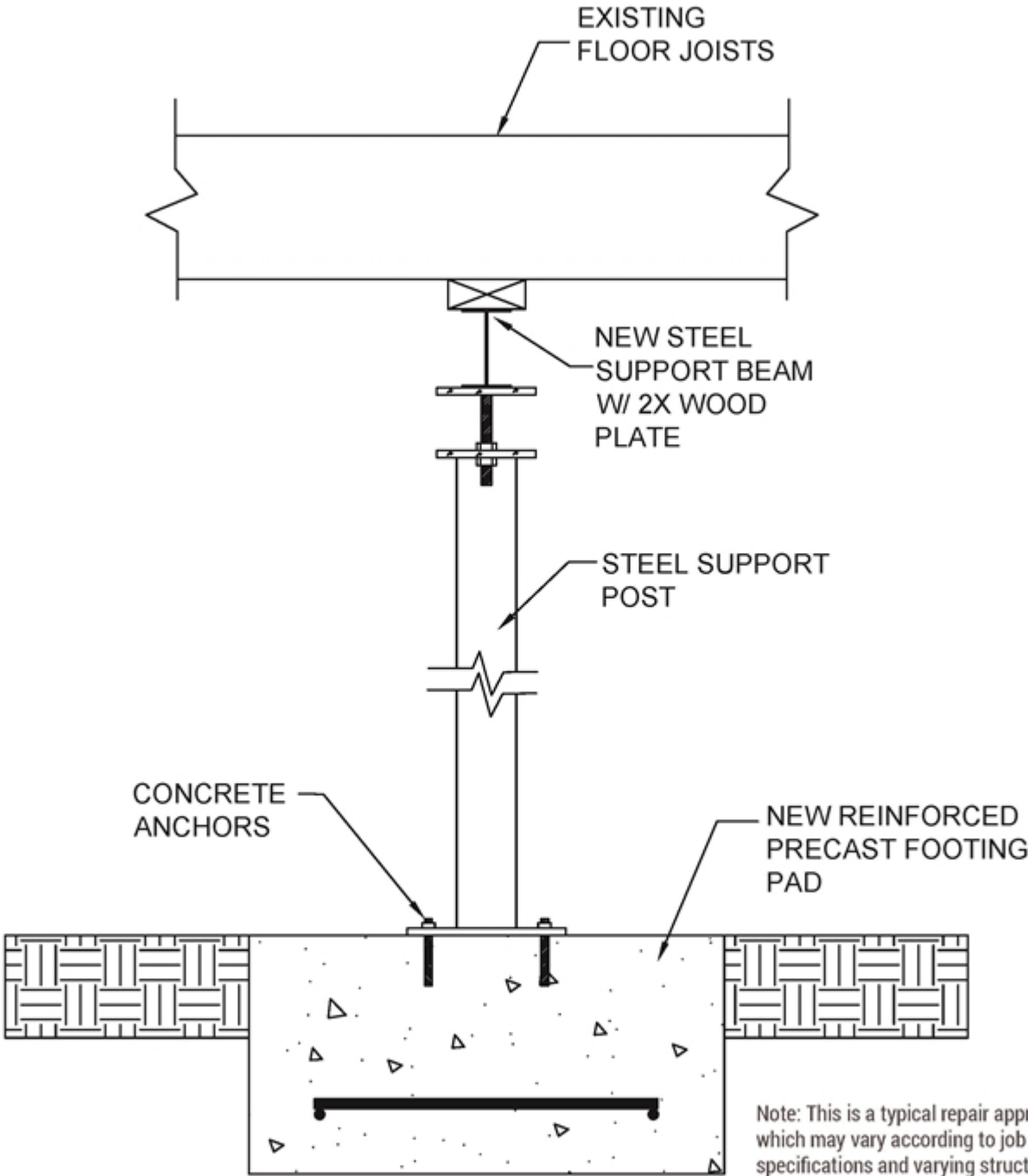



2111 Boat Factory Rd.
Pleasant View, TN 37146

BILL TO:

Warren Bainbridge
1906 Beechwood Avenue
Nashville, TN 37212

Job No: 150411

PROJECT SITE	COMPLETION DATE	TERMS
SAME	7/01/2015	Upon Completion

DESCRIPTION	AMOUNT
<p><u>REPAIR SERVICES:</u> Floor Support System w/Steel Jack Posts Install I-Beam with adjustable steel support post for floor support system</p>	<p>\$3,000.00</p> <p>\$400.00</p>
<p><i>I verify that all repair has been completed according to the USS agreement.</i></p> <hr/> <p>Customer Signature</p>	
<p>check# _____ date _____ amount _____</p> <p><i>* If paying by credit card, a 2.5% handling fee is applied.</i></p>	
<p>PAID IN FULL 7/1/2015</p>	

<p>Thank You For Your Business</p>	<p>Balance Due</p>	<p>3,400.00</p>
------------------------------------	--------------------	------------------------



UNITED STRUCTURAL SYSTEMS, INC.

5-Year Warranty

1906 Beechwood Avenue - Nashville, TN 37212

Property

This certifies that the structure located at the above address is warranted for 5-Years against defects in materials & workmanship in our area of steel floor support installation, to include free post adjustments, as needed.

This warranty is completely transferable to future owners at no cost.

07/01/2015

Completion Date

UNITED STRUCTURAL SYSTEMS
USS
inc.